



GB IE

# AIR BED

Operation and Safety Notes

6   
Z31196





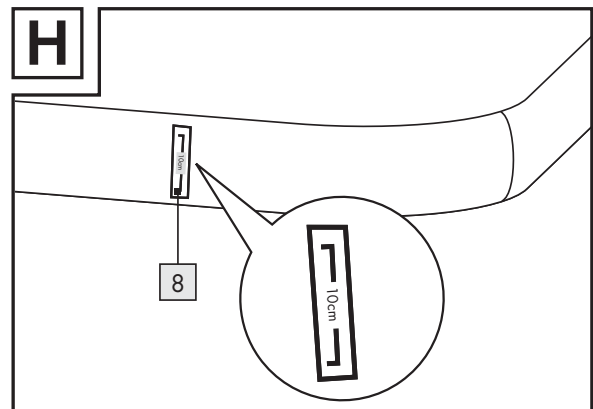
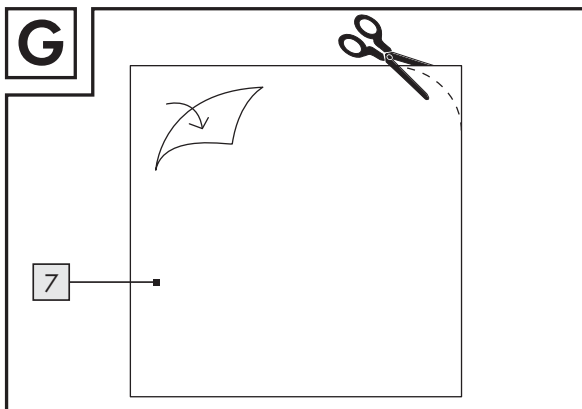
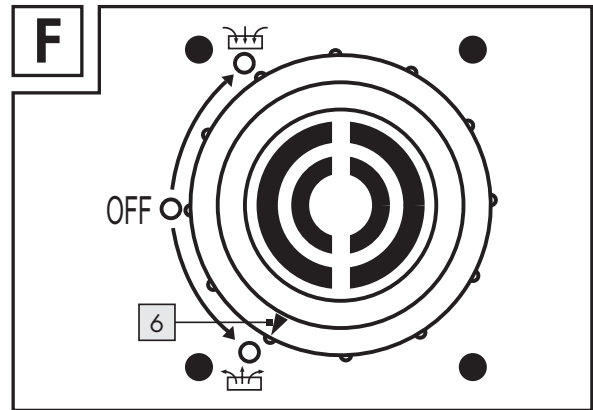
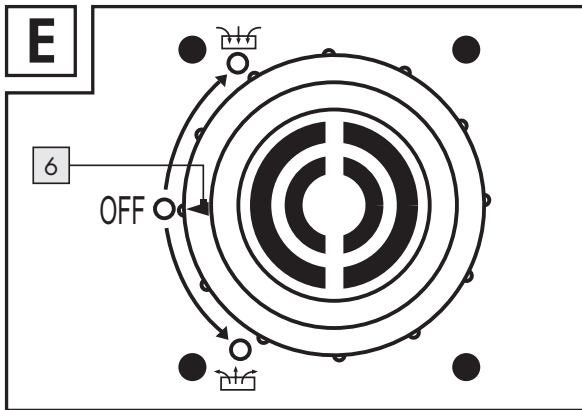
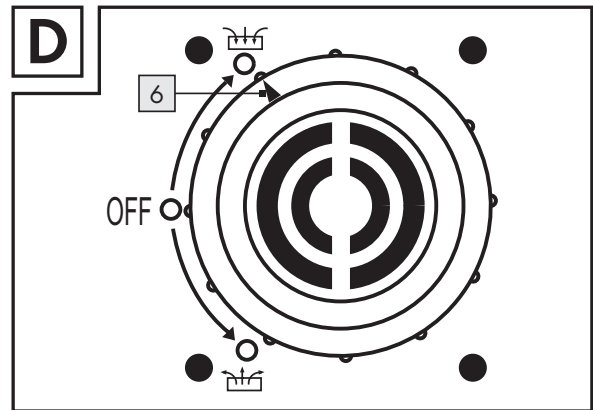
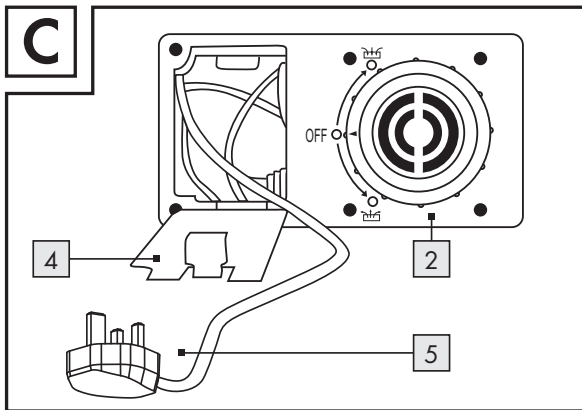
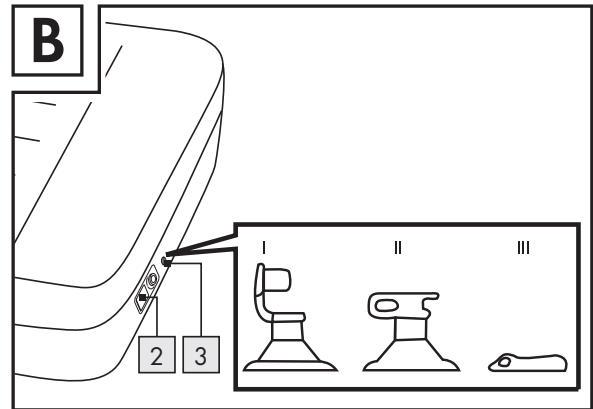
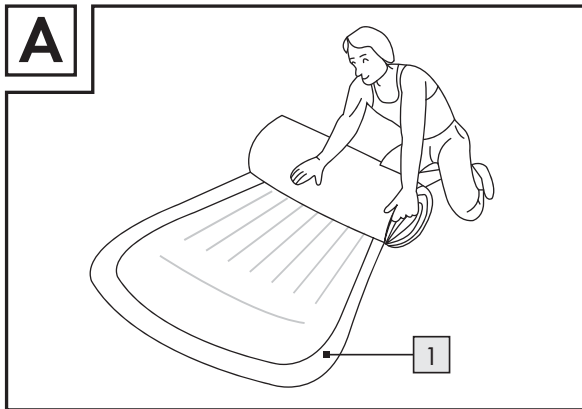

## Air Bed

### ● Intended Use

The product is intended for indoor use only as a mattress. The product is not intended for commercial use.

### ● Description of parts and features

- 1 Air bed
- 2 Pump
- 3 Air valve (optional)
- 4 Cover
- 5 Mains plug
- 6 Switch
- 7 Repair patch
- 8 Measuring strip

### ● Technical data

Dimensions: approx. 203 x 161 x 51 cm  
(l x w x d)  
Max. load: 250 kg  
Max. No. of persons: 1-2 adults  
Rated air pressure: 0.43 PSI (0.03 bar)

#### **Built-in Electric Air Pump**

Model no.: JL29P383G  
Rated voltage: 220-240V~ 50 Hz  
Rated power input: 130 W  
Protection class:

### ● Included items

- 1 Air bed with built-in electric air pump
- 2 Repair patches
- 1 Instructions for use



### Safety advice

**KEEP ALL THE SAFETY ADVICE AND INSTRUCTIONS IN A SAFE PLACE FOR FUTURE REFERENCE!**

- This appliance is not intended for use by persons (including children) with reduced physical, sensory or mental capabilities, or lack of experience and knowledge, unless they have been given supervision or instruction concerning use of the appliance by a person responsible for their safety.
- Children should be supervised to ensure that they do not play with the appliance.

**⚠ WARNING! DANGER TO LIFE!** Always keep the product out of reach of children under 3 years of age. The packaged product includes some small parts which could endanger life if swallowed or inhaled.

**⚠ CAUTION! RISK OF INJURY!** Make sure that all parts are undamaged. Damaged parts could adversely affect safety and function.

**⚠ CAUTION! RISK OF INJURY!** Do not use this product as a swimming aid.

**⚠ CAUTION!** Keep away from fire. Otherwise damage to the product can result.

- Please make sure that this product is placed on a level surface and not on any sharp or pointed objects. Otherwise damage to the product can result.

- Do not wash the product in the washing machine.

**⚠ CAUTION!** Ensure that the load placed on the product does not exceed 250 kg. Otherwise personal injury and/or damage to the product may result.

- Always use a suitable pump adapter with the air valve. Failure to observe this advice may result in damage to the air valve.



## Avoid the danger of death from electric shock!

- Before use, ensure that the mains voltage available is the same as the required operating voltage for the pump.
- Before connecting the device to the mains you should always check the device and the mains lead for any damage.
- A damaged device represents the danger of death from electric shock.
- Please consult a specialist electrician if you discover any damage or problems with the device, or for the performance of repairs to the device.
- Never open any of the electrical equipment or insert any objects into it. Such interventions represent the danger of death from electric shock.
- Never let the mains plug **5** and mains lead come into contact with water or other liquids.
- Never touch the mains plug with damp or wet hands.
- Do not use the mains lead for purposes for which it was not intended.
- Keep the mains lead away from heat, oil, sharp edges or moving parts of the device. Damaged or tangled mains leads increase the risk of electric shock.
- If the mains lead or mains plug of the pump is damaged, the pump **2** must be scrapped! It cannot be replaced!
- Observe the regulations governing connections to electrical power supply outlets applicable in your country before connecting the device. Contact an electrical specialist if you have any questions.
- Position the device and all electrical installations and connections in a place that cannot be flooded.
- Do not use an extension power cords with this product.
- Always remove the mains plug from the socket after pumping and deflating.
- Do not operate the electric pump for more than 5 minutes at one time. Take a 30 minutes break in between, as overheating may occur and pump will automatically shut off. It will be ready to use it has cooled down.

- Do not obstruct the air passage opening or insert any objects into the opening at any time.

## ● Operation

### ● Pumping up the air bed

**Note:** Before using the product for the first time, check it carefully for holes, porous places and seams that are not airtight.

**Recommendation:** Pump the product up and leave it alone for one day. Let a new product air outside in fresh air for a couple of days.

**⚠ CAUTION!** Inflatable plastic products react sensitively to the cold and hot. That is why you should never use the product when the ambient temperature falls to below 15 °C and rises above 40 °C. Otherwise damage to the product may result.

**Note:** Basically, only an adult should be responsible for pumping the airbed up. Make sure that you do not pump too much air into the product. On no account should you use a compressor. Stop the process when resistance increases during pumping and the seams start to stretch. Otherwise the material might tear. Only use manual pumps and/or pumps specifically designed for use with inflatable plastic products.

- Roll the product out and make sure the optional air valve **3** is securely closed (see Fig. B/III).
- Open the cover **4** on the pump **2** and take out the mains lead and mains plug **5** (see Fig. C).
- Insert the mains plug into the mains socket, and turn the switch **6** to "inflate" (see Fig. D). After approx. 3 ½ minutes the air bed **1** should be fully inflated and ready for use.
- Turn the switch to "OFF" to stop the process. (see Fig. E).
- Hold a ruler line at least 10 cm long up to the measuring strip **8**. The rated pressure is reached as soon as the measuring strip is 10 cm long (see Fig. H). The ruler is not included with the product.
- If necessary, turn the switch to "deflate" to let a little air escape (see Fig. F).

- Disconnect the mains plug from the mains socket and place it inside the compartment of the pump.

## ● Deflating the air bed

- Open the cover **4** on the pump **2** and take out the mains lead and mains plug **5** (see Fig. C).
- Insert the mains plug into the mains socket, and turn the switch **6** to “deflate” (see Fig. F). The air bed **1** should be fully deflated after approx. 4 minutes.
- Turn the switch to “OFF” (see Fig. E).
- Disconnect the mains plug from the mains socket and place it inside the compartment.

**Note:** When the air bed **1** is not completely deflated, turn the switch **6** to the deflating mark (see Fig. F). Begin rolling the air bed from the foot of the air bed towards the head of the airbed where the pump **2** is located. Repeat this step until the airbed is fully deflated. Turn back the switch to “OFF” position.

## ● Maintenance

### ● Mending the air bed

**Note:** Minor damage may be repaired using the supplied repair patch. Have any major damage carried out at a specialist repair shop.

- First let the air out of the product (see “Deflating the air bed”).
- Clean the damaged area with alcohol.
- Abrade the area around the site of the damage with fine sandpaper.
- Cut a piece out of the plastic film of the repair patch **7**.

**Note:** Make sure that the repair patch largely overlaps the edges of the leak.

- Peel off the protective film from the back of the repair patch.
- Round the corners off and place the repair patch over the leak or hole.
- Place the repair patch onto the damaged part.

- Press the repair patch firmly down onto the leak. You may have to place a heavy object onto the relevant area.
- Wait for 24 hours before you pump up the product again.

## ● Cleaning and care

- Do not under any circumstances use corrosive or abrasive cleaning agents. These may damage the surface of the product.
- Clean the flocked surface of the product using a brush.
- Clean the plastic surfaces with water and/or a little mild soap solution.
- Ensure that the inside and outside of the product are completely dry if you intend to store it indoors for a long period. Failure to observe this advice could result in the build-up of mildew and mould.
- Fold up the product with the flocked surface on the inside.
- Store the product in dark, dry place – out of reach of children.
- The ideal storage temperature is between 10 and 20 °C.
- Do not allow sharp objects to come into contact with the product while it is in storage.
- Never powder the product with talcum.
- Make sure that the optional air valve **3** is shut and turn the switch **6** to the “OFF”, if you want to store the product for a long period.

## ● Disposal



The packaging is wholly composed of environmentally friendly materials that can be disposed of at a local recycling centre.

Contact your local refuse disposal authority for more details of how to dispose of your worn-out product.



In the interest of the environment, do not throw out your product with your household refuse. Take it to a suitable centre where it can be disposed of properly. Your local council will be able to tell you where the collection centres are located and their opening times.

Observe the applicable regulations. In case of doubt, please contact your waste disposal centre.

**EMC CE**



IAN 73551

**Milomex Ltd.** 

c/o Milomex Services

Hilltop Cottage

Barton Road

Pulloxhill

Bedfordshire

MK45 5HP

UK

Model-No.: Z31196

Version: 05/2012

© by **ORFGEN Marketing**

Last Information Update: 05/2012

Ident.-No.: Z31196-BS052012-6

